

UNDERNEATH MARK
USF XX, ASTM-A48
CLASS 35B, DATE.

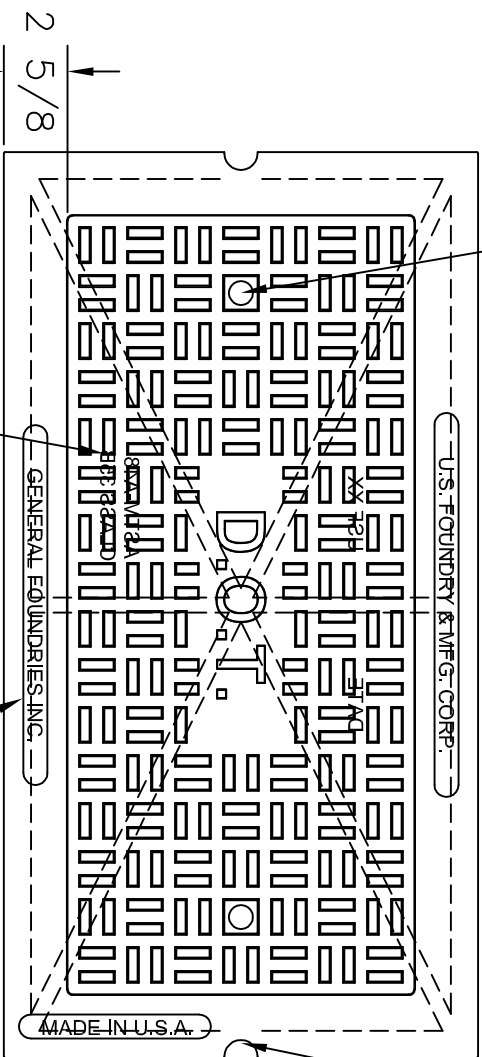
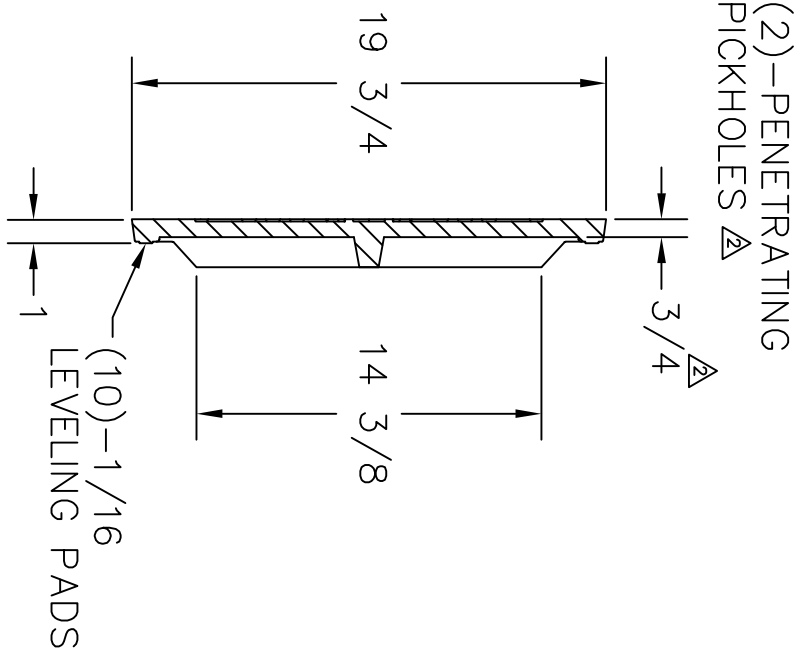
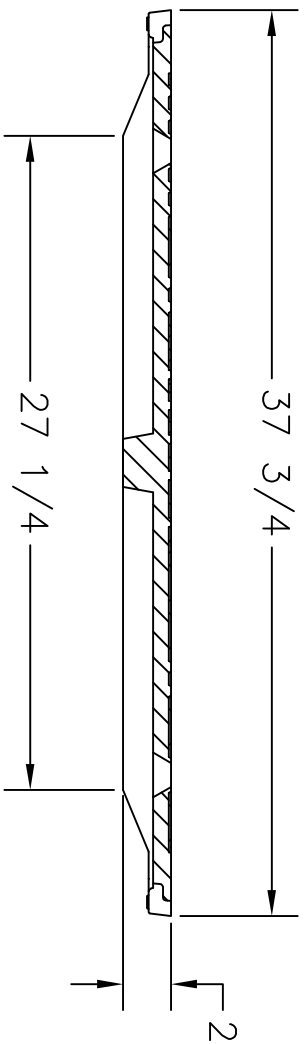

U.S. FOUNDRY & MFG. CORP.
MEDLEY, FLORIDA

DESCRIPTION: USF COVER
18" x 36" NJ DOT JUNCTION BOX COVER
MATERIAL: ASTM-A48 GRAY IRON CLASS: 35B
FRAME WEIGHT: COVER WEIGHT: 160

UNLESS OTHERWISE NOTED WEIGHT IS IN POUNDS AND APPROXIMATED

2	08-26-09	MODIFIED REF: DWG NJ DOT L-0601	ULS	DWN. BY: ULS	SCALE: 1/8"=1"	ITEM No: 8015518	DWG. No:	DWG DATE: 07-14-09
1	07-14-09	ADD MORE WEIGHT 140 LBS WAS NOW 155 LBS	ULS	CHK. BY:				REV: 2